

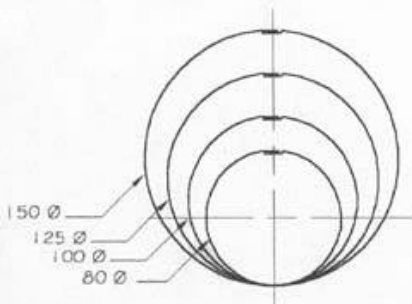

COPPERFORM DATA SHEET RAINWATER GOODS

The Information in this literature is correct at the time of printing. However, specifications are subject to change without notice. Copperform roofing panels and associated products will perform as specified if fixed strictly in accordance with good trade and practice recommendations.

ROOF AREA TO BE DRAINED	HOBART	ADELAIDE/ MELBOURNE	PERTH	SYDNEY	BRISBANE	DARWIN
50m ² RECT D/P	100 x 50 OR	100 x 50 OR	100 x 50 OR	100 x 50 OR	100 x 75 OR	100 x 75 OR
ROUND D/P	80 dia	80 dia	80 dia	80 dia	100 dia	100 dia
80m ² RECT D/P	100 x 50 OR	100 x 50 OR	100 x 50 OR	100 x 50 OR	100 x 75 OR	100 x 75 OR
ROUND D/P	80 dia	80 dia	80 dia	80 dia	100 dia	100 dia
100m ² RECT D/P	100 x 50 OR	100 x 50 OR	100 x 50 OR	100 x 50 OR	100 x 75 OR	100 x 75 OR
ROUND D/P	80 dia	80 dia	80 dia	80 dia	100 dia	100 dia



DOWNPIPE CHART

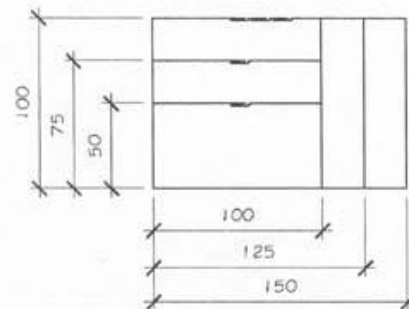

Copperform
Creating heritage



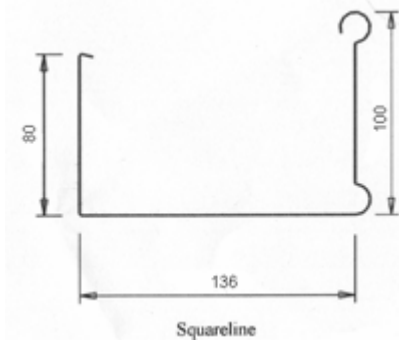
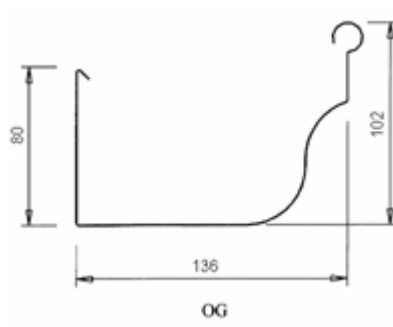
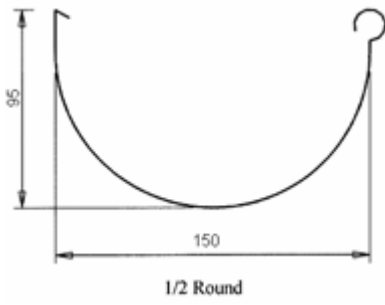
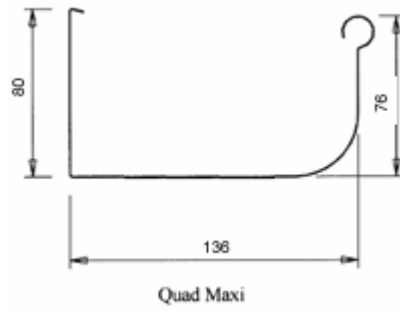
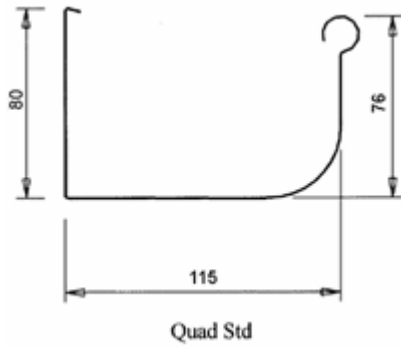

2.0 TOTAL SPECIFICATIONS

2.1 System Weight

Material	Weight (Kg per m ²)
Plywood	9.75
Copper	6.25
Total	16.00

2.2 Acoustic Performance

Rain noise in a room below a Copperform roof will be approximately 28dBA quieter than below an un-insulated Custom Orb steel roof deck. (Note: A 10 dBA reduction is a halving of loudness and a 20 dBA reduction is a quarter of the loudness. Hence 28 dBA is almost one eighth the loudness of an un-insulated Custom Orb steel roof).

2.3 Thermal Performance

R value – 1.527 m² k /W

U value – 0.654 W/ m² k

These values include the thermal performance of the copper, plywood and attic air space. Further insulation will increase these values.

3.0 COPPER SPECIFICATIONS

Copperform roofing panels are manufactured from sheet copper to AS 1566 standards

3.1 Physical Properties of Copper roofing panels

Nominal Gauge	0.55 mm
Panel Weight	4.9 kg/m ²
Density	8940 kg/m ³
Melting Point	1083 °C
Composition	99.98% pure copper

3.2 Performance criteria of copper roofing panels

Fire / Flame Spread	Copper is non-combustible. The very high thermal conductivity of copper allows a passage of heat away from the heat source
Heat	As an excellent conductor of heat, copper heats up and cools down quickly.
UV	Together with moisture, UV actually assists in the patination process. This increases the protective surface
Biological	The excellent biological control characteristics of copper will not support the growth of lichens, fungi or algae and this is now being widely recognized and being applied in sterile environments, such as hospitals.
Chemical	Copper is resistant to most industrially generated airborne pollutants. In fact, sulphides, chlorides etc, in industrial smog actually accelerate the development of oxidization of the surface and the patina or protective coating. Copper is only attacked by strong oxidizing chemicals and acids such as hydrochloric, sulphuric or nitric acids. Fuel spills such as diesel, petrol, kerosene, etc will have no adverse effect on the performance of copper.

3.3 Compatibility

The Copperform roofing system has been designed to ensure the compatibility of all its components. Care should be taken that direct contact with or water run-off from copper does not adversely affect less noble materials such as steel, aluminum, zinc, etc.

Water run-off from bitumen and western red shingles will attack copper

Roof extras such as antennas, flue pipes, railings etc. could discolor copper roofing unless correctly flashed. Should there be any doubt as to the compatibility of materials with Copperform components, please contact the Copperform Advisory Service.